



Cambridge O Level

CANDIDATE
NAME

--

CENTRE
NUMBER

--	--	--	--	--

CANDIDATE
NUMBER

--	--	--	--



PHYSICS

5054/21

Paper 2 Theory

October/November 2022

1 hour 45 minutes

You must answer on the question paper.

No additional materials are needed.

INSTRUCTIONS

- Section A: answer **all** questions.
- Section B: answer **two** questions.
- Use a black or dark blue pen. You may use an HB pencil for any diagrams or graphs.
- Write your name, centre number and candidate number in the boxes at the top of the page.
- Write your answer to each question in the space provided.
- Do **not** use an erasable pen or correction fluid.
- Do **not** write on any bar codes.
- You may use a calculator.
- You should show all your working and use appropriate units.

INFORMATION

- The total mark for this paper is 75.
- The number of marks for each question or part question is shown in brackets [].

This document has **20** pages. Any blank pages are indicated.

Section A

Answer **all** the questions in this section. Answer in the spaces provided.

- 1 Fig. 1.1 shows a steel spring.

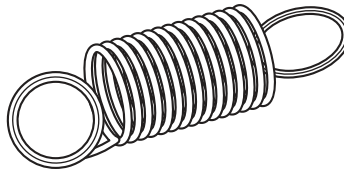

Fig. 1.1

- (a) Describe an experimental procedure for obtaining the results needed to plot an extension–load graph for this spring.

.....

.....

.....

.....

.....

.....

..... [3]

- (b) In an experiment to obtain results for an extension–load graph, a spring is stretched beyond its limit of proportionality.

- (i) On Fig. 1.2, sketch the extension–load graph for this spring.

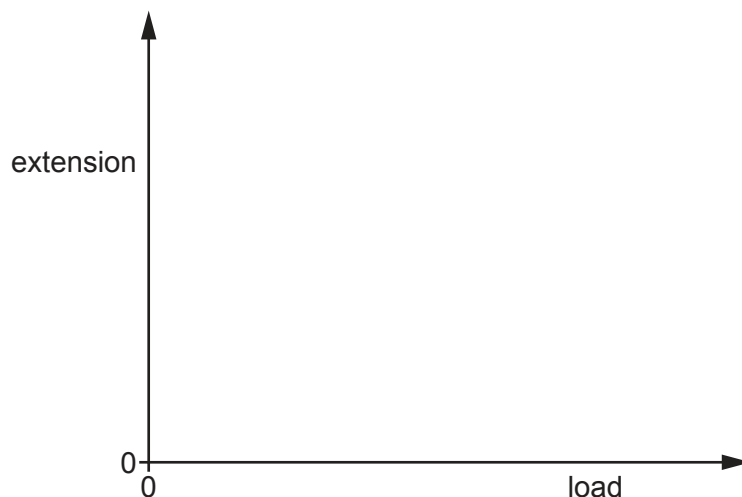

Fig. 1.2

[2]

- (ii) On your graph in Fig. 1.2, mark and label with a P the limit of proportionality.

[1]

(c) The limit of proportionality for this spring occurs at a load of 8.5 N.

The extension of the spring is equal to 0.014 m when the load is equal to 3.5 N.

Calculate the extension for a load of 5.5 N.

extension = [2]

[Total: 8]

- 2 A child's toy consists of a flexible track and a model car.

Fig. 2.1 shows a diagram of the toy.

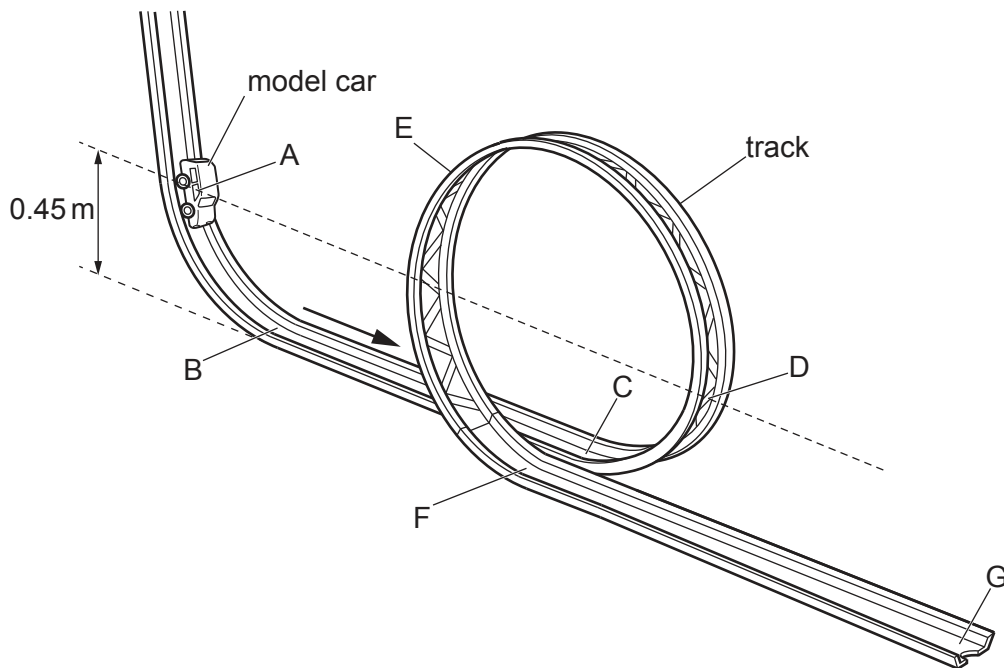

Fig. 2.1

The child first holds the car stationary at point A which is 0.45 m above the horizontal sections of track BC and FG. The mass of the car is 0.12 kg.

The child then releases the car which travels towards point B. Both air resistance and friction between the car and the track are negligible.

The gravitational field strength g is 10 N/kg.

- (a) Calculate the change in gravitational potential energy (g.p.e.) of the car as it travels from A to B.

change in g.p.e. = [2]

(b) Calculate the speed of the car when it reaches B.

speed = [3]

(c) After releasing it, the child expects the car to follow the track along the route ABCDEFG. In fact, the model car does not reach F.

(i) Explain, in terms of energy, why the car does not go past D, which is also 0.45 m above the horizontal track.

.....
..... [1]

(ii) Immediately after being released at A, the car travels to B, to C and then to D.

Describe the motion of the car after it reaches D.

.....
..... [1]

[Total: 7]

3 A curved, glass tube is open at one end and sealed at the other.

A dense liquid is poured into the tube. The liquid traps air in the sealed end.

Fig. 3.1 shows the tube, the liquid and the trapped air.

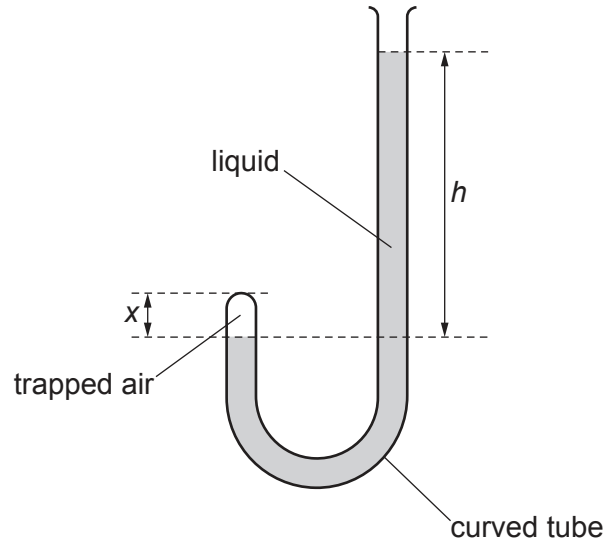

Fig. 3.1

(a) The difference between the liquid levels is h . At room temperature, h is 0.57 m.

The density of the liquid is $1.4 \times 10^4 \text{ kg/m}^3$.

The gravitational field strength g is 10 N/kg and the atmospheric pressure is $1.0 \times 10^5 \text{ Pa}$.

Calculate the pressure of the trapped air.

pressure = [3]

(b) The trapped air in the tube is heated.

(i) The height of the trapped air in the tube is x .

Explain, in terms of molecules, why x changes when the air is heated.

.....
.....
.....
.....
..... [3]

(ii) The trapped air reaches a constant temperature that is greater than its initial temperature.

Describe and explain the change in h in terms of the pressures involved.

.....
.....
.....
..... [2]

[Total: 8]

4 X-rays are transverse waves that are part of a spectrum of waves.

(a) State the name of the spectrum of waves that includes X-rays.

..... [1]

(b) (i) Explain what is meant by 'frequency'.

.....
.....
..... [2]

(ii) State the name of the waves in this spectrum that have the greatest frequency.

..... [1]

(c) X-rays are used in hospitals to produce an image of broken bones.

(i) Explain how this is done. You may draw a diagram if you wish.

.....
.....
.....
..... [3]

(ii) Explain why X-rays are **not** used for pre-natal scanning.

.....
..... [1]

[Total: 8]

5 Fig. 5.1 is a diagram that shows the number of particles in a charged atom (ion) of beryllium (Be).

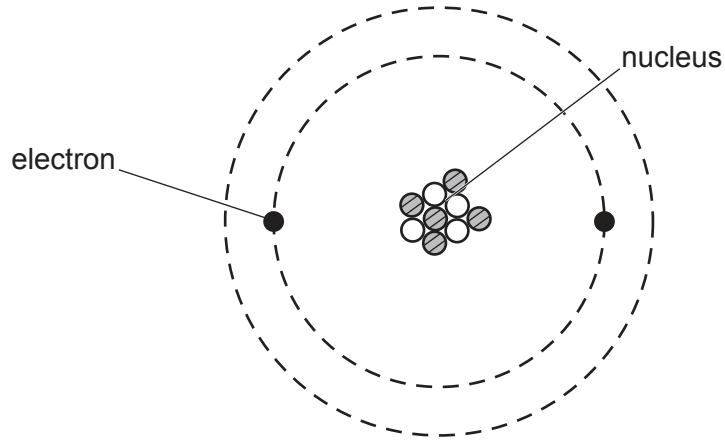

Fig. 5.1

(a) The charge on an electron is $-1.6 \times 10^{-19} \text{C}$. The charge on the ion is $+3.2 \times 10^{-19} \text{C}$.

(i) Deduce, from the charge on the ion, the number of protons in its nucleus.

Show your working.

number of protons = [2]

(ii) Write down, in nuclide notation, the symbol for the nucleus of this charged atom.

..... [1]

(b) The isotope in Fig. 5.1 is the only stable isotope of beryllium.

Explain the term 'isotope'.

.....

 [2]

(c) Explain what prevents electrons in an atom from escaping.

.....

 [2]

[Total: 7]

- 6 An electromagnet is used to separate objects that are magnetic from objects that are non-magnetic.

Fig. 6.1 shows the electromagnet suspended from the arm of a crane.

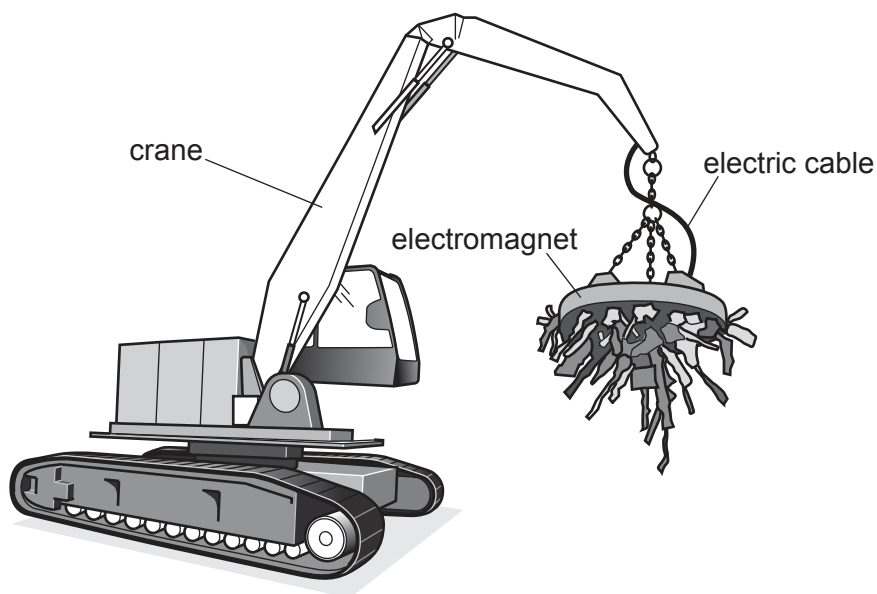

Fig. 6.1

- (a) State the name of the metal from which the core of the electromagnet is made.

..... [1]

- (b) The electromagnet is powered by a 220V d.c. (direct current) supply.

The electromagnet is switched on and the current in the circuit is 39A.

- (i) Calculate the power transferred to the electromagnet.

power = [2]

(ii) The d.c. supply is a set of batteries.

The batteries power the magnet for 4.5 hours before they need to be replaced.

Calculate the charge driven around the complete circuit in this time.

charge = [3]

(c) On a very cold morning, when the electromagnet is first switched on, the current is greater than 39A before decreasing to the usual value.

Explain why the current is initially greater than 39A.

.....
..... [1]

[Total: 7]

Section B

Answer **two** questions from this section. Answer in the spaces provided.

- 7 Fig. 7.1 shows a child sitting on a sledge on a snow-covered hill of constant slope.

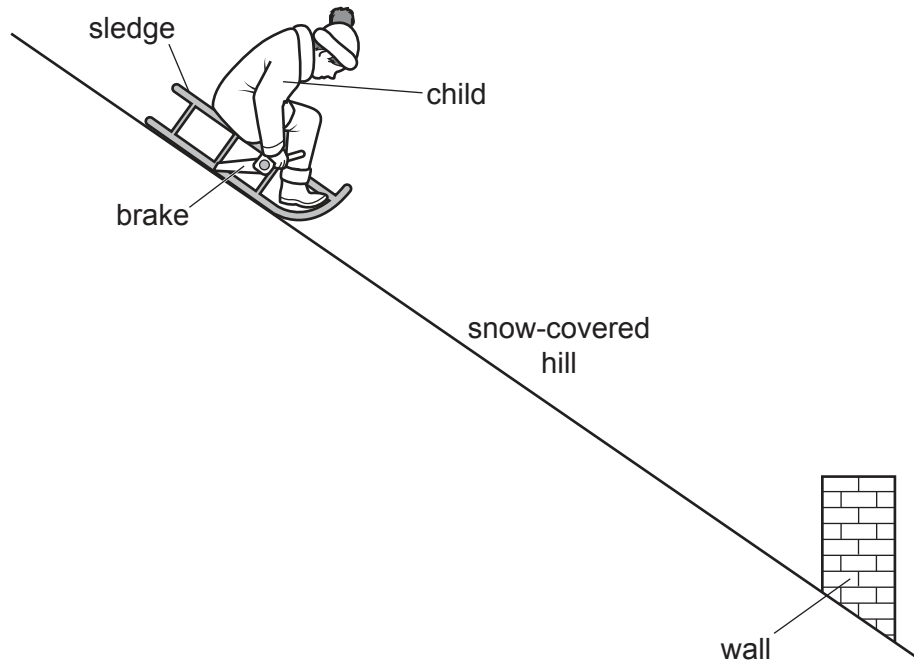

Fig. 7.1 (not to scale)

At time $t = 0$, the child and the sledge begin to move down the hill in a straight line.

When the child sees a wall ahead, he applies the brake.

The child and sledge continue to travel in a straight line until they come to a stop before hitting the wall.

Fig. 7.2 is the speed-time graph for the journey.

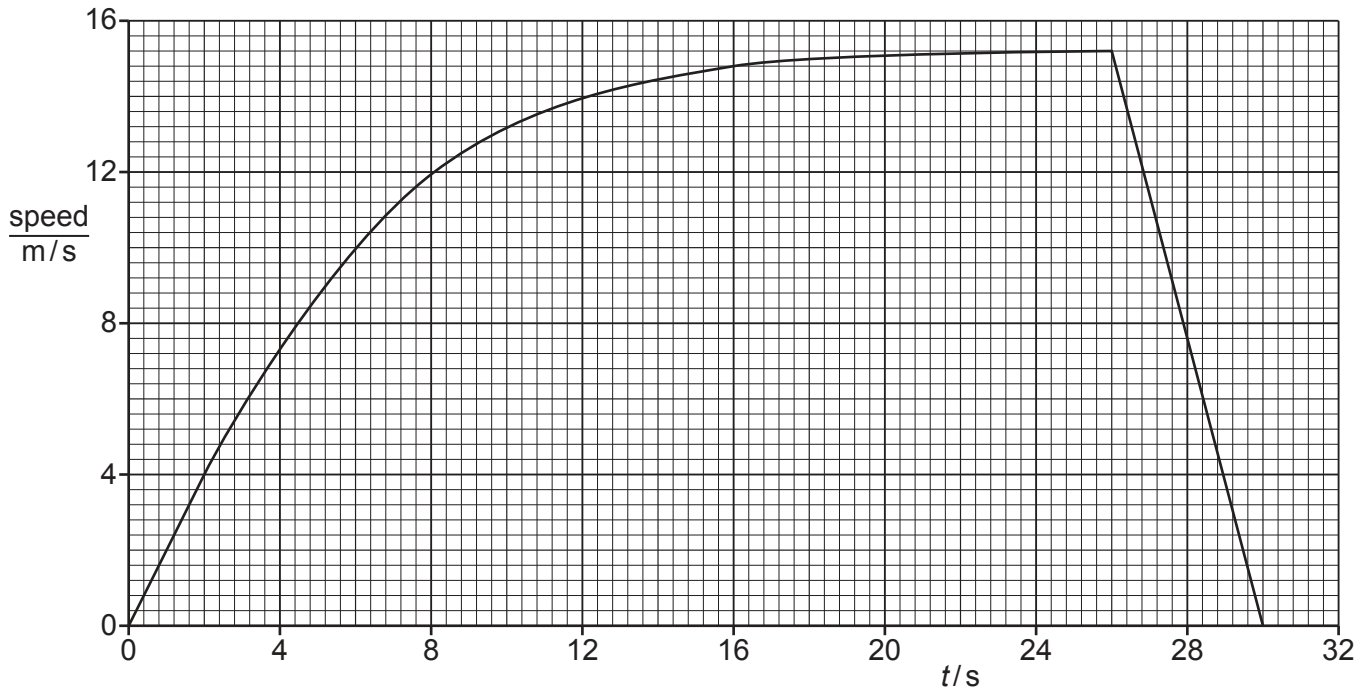

Fig. 7.2

The brake is applied at $t = 26$ s.

(a) Fig 7.2 shows how the speed of the child and sledge varies over the whole of the journey.

Explain why, between $t = 0$ and $t = 26$ s, the speed varies in the way shown by the graph.

.....

.....

.....

.....

.....

.....

..... [3]

(b) At $t = 26$ s, the front of the sledge is 35 m from the wall.

Determine the distance between the front of the sledge and the wall when the sledge stops.

distance = [3]

(c) At $t = 26$ s, the child and sledge begin to decelerate.

(i) Determine the size of the deceleration.

deceleration = [3]

(ii) The mass of the child is 46 kg and the mass of the sledge is 9.0 kg.

Calculate the resultant force on the child and sledge as they decelerate.

resultant force = [2]

(iii) State the energy transfer that is taking place as the child and sledge decelerate.

.....
.....
..... [2]

(d) At $t = 26$ s, when the brake is first applied, the child jerks forwards on the sledge.

Explain why.

.....
.....
..... [2]

[Total: 15]

8 A parallel beam of light travelling in air is incident on a glass lens.

The beam is perpendicular to the lens as shown in Fig. 8.1.

The dashed line P indicates the position of the lens. The centre of the lens is dot C.

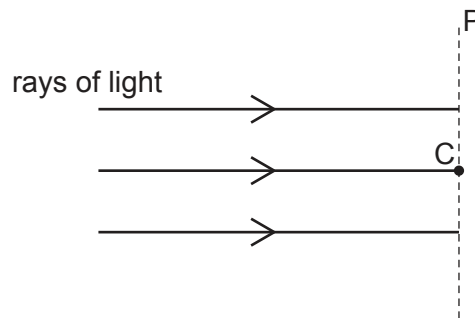

Fig. 8.1

(a) The lens is a diverging lens.

On Fig. 8.1:

(i) indicate the shape of the lens by drawing the outline of the lens around dashed line P [1]

(ii) draw the path taken by each ray of light after it passes through the lens. [2]

(b) Diverging lenses are used to correct short-sight.

(i) Fig. 8.2 is a simplified diagram of a short-sighted eye. Light from a distant object strikes the eye lens and enters the eye.

On Fig. 8.2, continue the three rays in the eye until they reach the back of the eye.

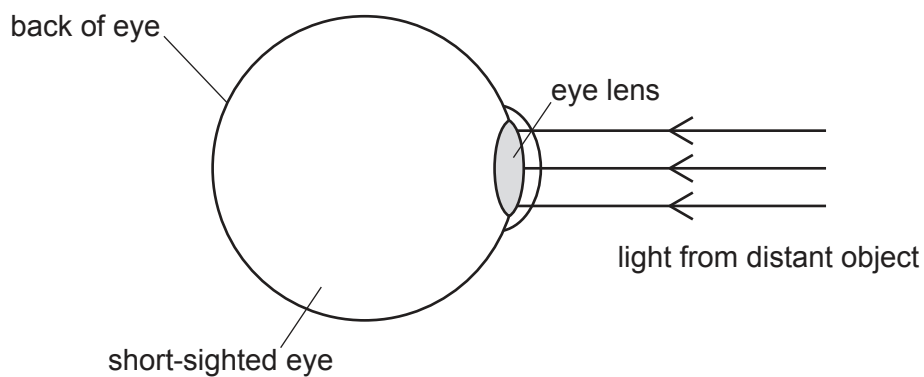

Fig. 8.2

[2]

- (ii) State how the image of a distant object detected by a normal eye differs from the image detected by the short-sighted eye.

.....
 [1]

- (iii) Explain how a diverging lens corrects the sight of a short-sighted eye viewing a distant object.

.....
 [1]

(c) The focal length of the diverging lens is 4.0 cm.

An object of height 3.5 cm is placed 6.0 cm from the centre of the lens.

- (i) Fig. 8.3 is a full-scale diagram drawn on a grid, on which the dashed line L represents the lens and the arrow O the object.

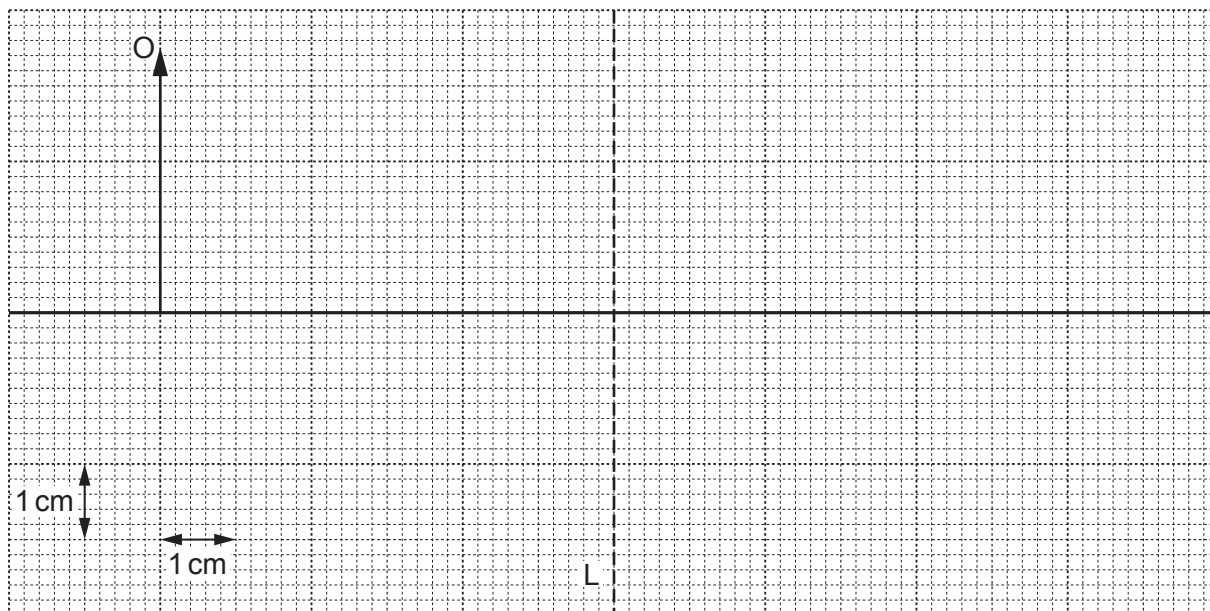

Fig. 8.3

By drawing on Fig. 8.3, find the position of the image I of object O. Draw image I and label it I. [4]

- (ii) Explain whether the image produced is real or virtual.

.....
 [1]

- (iii) On the grid in Fig. 8.3, write an E in a position from which an eye can see the image. [1]
- (iv) Determine the linear magnification produced.

linear magnification = [2]

[Total: 15]

9 The power supply in an electric circuit is a battery of electromotive force (e.m.f.) 12 V.

(a) State **two** ways in which the e.m.f. of a battery differs from that of an alternating current (a.c.) power supply.

1

2

[2]

(b) The circuit includes three resistors and two open switches, S_1 and S_2 .

Fig. 9.1 shows the circuit.

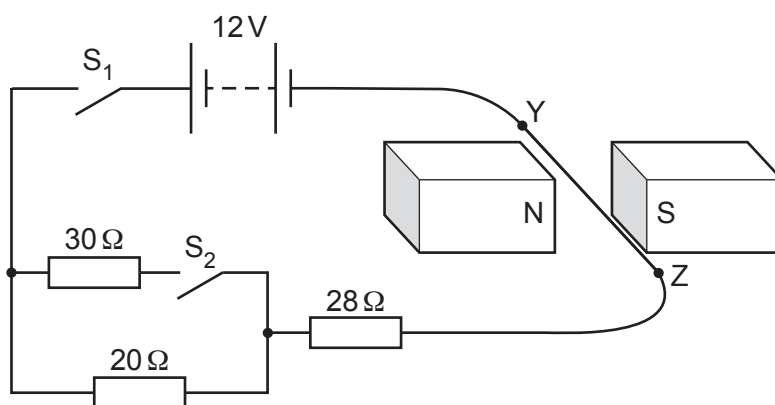

Fig. 9.1

YZ is a straight, horizontal section of connecting wire that lies between two magnets.

S_1 is now closed.

(i) Calculate the current in YZ.

current = [2]

(ii) Explain why YZ experiences a force.

.....

 [2]

(iii) Tick the box which describes the direction of the force on YZ.

towards N	<input type="checkbox"/>	towards Z	<input type="checkbox"/>
towards S	<input type="checkbox"/>	downwards	<input type="checkbox"/>
towards Y	<input type="checkbox"/>	upwards	<input type="checkbox"/>

[1]

(iv) Explain how the direction of the force on YZ is determined.

.....

.....

..... [2]

(c) Switch S_2 in the circuit in Fig. 9.1 is now also closed.

(i) Calculate the total resistance of the circuit.

resistance = [3]

(ii) Explain what happens to the force on YZ as switch S_2 is closed.

.....

.....

..... [2]

(iii) The current in the $20\ \Omega$ resistor is I_{20} . The current in the $30\ \Omega$ resistor is I_{30} .

State a value for the ratio I_{20}/I_{30} .

ratio $I_{20}/I_{30} = \dots\dots\dots$ [1]

[Total: 15]

BLANK PAGE

Permission to reproduce items where third-party owned material protected by copyright is included has been sought and cleared where possible. Every reasonable effort has been made by the publisher (UCLES) to trace copyright holders, but if any items requiring clearance have unwittingly been included, the publisher will be pleased to make amends at the earliest possible opportunity.

To avoid the issue of disclosure of answer-related information to candidates, all copyright acknowledgements are reproduced online in the Cambridge Assessment International Education Copyright Acknowledgements Booklet. This is produced for each series of examinations and is freely available to download at www.cambridgeinternational.org after the live examination series.

Cambridge Assessment International Education is part of Cambridge Assessment. Cambridge Assessment is the brand name of the University of Cambridge Local Examinations Syndicate (UCLES), which is a department of the University of Cambridge.